

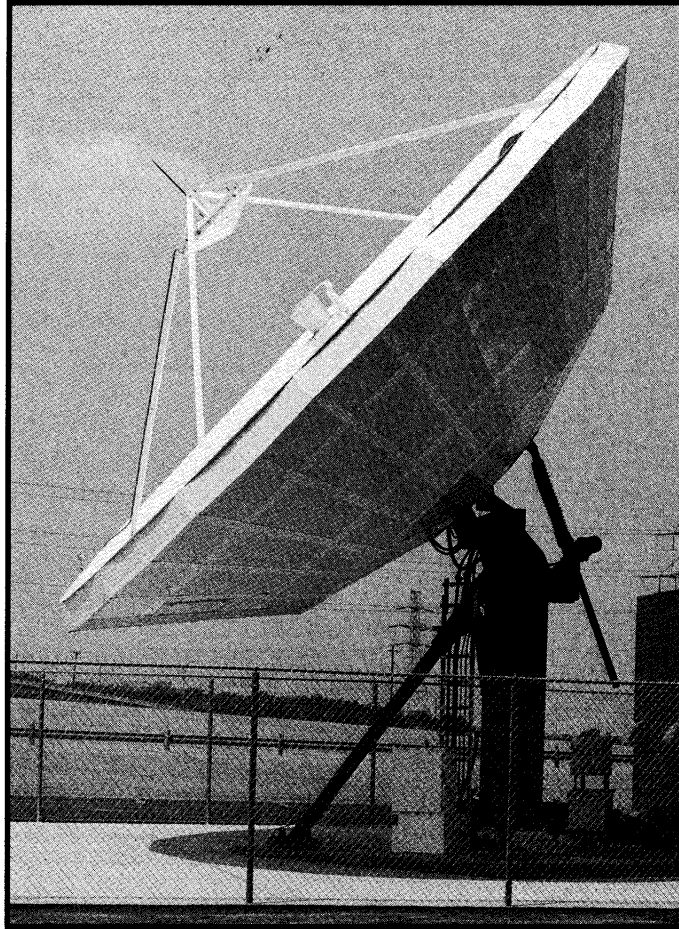

VERTEX 9-METER

MODEL 9 KPC & KPK (Kingpost Pedestal)

C-BAND and KU-BAND



EARTH STATION ANTENNAS

Vertex has developed the 9-Meter C-Band and Ku-Band antennas to offer superior performance for receive-only and transmit-receive worldwide applications.

Model 9 KPC (C-Band) and 9 KPK (Ku-Band) antennas incorporate stretch-formed, doubly contoured panels with matched radials and hub assemblies for ease of field alignment. The reflectors and azimuth/elevation kingpost pedestals provide the stiffness and pointing accuracy required for C-Band and Ku-Band operation. These antennas are designed for full orbital arc coverage and are readily adaptable to ground or rooftop installations.

The antennas meet FCC Regulation 25.209, Eutelsat requirements for antenna pattern and polarization discrimination, and INTELSAT requirements as specified in associated IESS documents.

Options:

- Two-port, three-port, four-port Rx/Tx linear and circular polarized feeds
- Reflector and feed deicing systems with manual or automatic controls
- Manual or motorized azimuth, elevation and polarization drive systems with controls and readouts
- Steptrack control system with readouts
- Turnkey installations or installation assistance
- Extended Azimuth Travel Pedestal System, 180° – 2 Positions

VERTEX COMMUNICATIONS CORPORATION

2600 LONGVIEW ST. • P.O. BOX 1277 • KILGORE, TX 75663 • TEL 903-984-0555 • FAX 903-984-1826

9-METER KPC/KPK MECHANICAL SPECIFICATIONS

Azimuth Travel	120° continuous* (Standard) / 180° 2-Position (Optional)
Azimuth Travel Rate	.4°/second C-Band; .2°/second Ku-Band**
Elevation Travel	5° to 90° continuous
Elevation Travel Rate	.4°/second C-Band; .2°/second Ku-Band**
Polarization Travel	±95° (2-Port) / ±50° (4-Port)
Polarization Travel Rate	1.5°/second
Weight - Reflector	4,200 pounds (1,905 kg)
Weight - Pedestal	3,200 pounds (1,450 kg)
Shipping Weight (Typical)	12,000 pounds (5,443 kg)
Shipping Volume	2,180 cubic feet (63 m ³)
Reflector Structure	Aluminum
Pedestal Structure	Steel
Finishes Reflector Surface Pedestal	Aluminum panels with heat-diffusing white paint Red oxide primer and two coats of enamel
Surface Accuracy	0.018 inch (static) (Ku-Band) / 0.025 inch (static) (C-Band)
Foundation Size	22 ft x 22 ft x 1.5 ft (6.7 m x 6.7 m x 0.46 m)
Concrete Volume	27 cubic yards (20.7 m ³)
Reinforcing Steel	3,360 pounds (1,524 kg)
Soil Bearing Pressure	2,000 PSF (10,000 kg/m ²)

* Extended Travel Option Available ±95°

** Optional Rates Available

9-METER KPC/KPK ENVIRONMENTAL SPECIFICATIONS

Operational Winds	45 mph (72 km/h); gusts to 60 mph (97 km/h)
Survival Winds	125 mph (200 km/h) @ 58°F (15°C)
Ambient Temperature	-20°C to +50°C (survival) / -15°C to +50°C (operational)
Rain (Operational and Survival)	Up to 4 in/h (10 cm/h)
Relative Humidity (Operational and Survival)	0% to 100% with condensation
Solar Radiation	360 BTU/h/ft ² (1000 Kcal/h/m ²)
Radial Ice (Survival)	1 inch (2.5 cm) on all surfaces or 1/2 inch (1.3 cm) on all surfaces with 80 mph (130 km/h) wind gusts
Shock and Vibration	As encountered during shipment by commercial air, rail or truck
Corrosive Atmosphere	As encountered in coastal regions and/or heavily industrialized areas
Seismic (Survival)	0.3 G's horizontal 0.1 G's vertical

NOTE: This document gives a description of only the prominent features of the product(s). Vertex reserves the right to change the specifications without notice.

VERTEX COMMUNICATIONS CORPORATION

2600 LONGVIEW ST. • P.O. BOX 1277 • KILGORE, TX 75663 • TEL 903-984-0555 • FAX 903-984-1826

9-METER KPC/KPK R.F. SPECIFICATIONS	C-BAND 4-PORT CIRC. POL FEED		C-BAND 4-PORT LINEAR POL FEED		KU-BAND 2-PORT LINEAR POL FEED		KU-BAND 4-PORT LINEAR POL FEED	
	RECEIVE	TRANSMIT	RECEIVE	TRANSMIT	RECEIVE	TRANSMIT	RECEIVE	TRANSMIT
	3.625-4.200	5.850-6.425	3.700-4.200	5.925-6.425	10.95-12.75	14.00-14.50	10.95-12.75	14.00-14.50
Frequency in GHz*	3.625-4.200	5.850-6.425	3.700-4.200	5.925-6.425	10.95-12.75	14.00-14.50	10.95-12.75	14.00-14.50
Antenna Gain	49.3 dB	53.2 dB	49.5 dB	53.3 dB				
3.625/5.850 GHz		53.5 dB		53.5 dB				
3.700/5.925 GHz	50.0 dB		50.1 dB		58.5 dB	60.4 dB	58.4 dB	60.3 dB
3.912/6.138 GHz		53.8 dB	50.6 dB	53.8 dB	59.1 dB	60.5 dB	59.0 dB	60.4 dB
3.950/6.175 GHz	50.6 dB				59.7 dB	60.5 dB	59.6 dB	60.4 dB
4.200/6.425 GHz								
10.950/14.000 GHz								
11.850/14.250 GHz								
12.750/14.500 GHz								
Antenna Noise Temperature								
5° Elevation	51°K		49°K		74°K		79°K	
10° Elevation	39°K		37°K		57°K		63°K	
20° Elevation	31°K		29°K		47°K		53°K	
40° Elevation	28°K		26°K		43°K		48°K	
Typical G/T at 20° Elevation, 3.912 GHz, Clear Horizon	31.1 dB/K							
with 40°K LNA	29.9 dB/K							
with 65°K LNA								
Typical G/T at 20° Elevation, 3.950 GHz, Clear Horizon			31.3 dB/K					
with 40°K LNA			30.1 dB/K					
with 65°K LNA								
Typical G/T at 20° Elevation, 11.850 GHz, Clear Horizon								
with 90°K LNA					37.4 dB/K		37.2 dB/K	
with 150°K LNA					35.9 dB/K		35.7 dB/K	
Pattern Beamwidth in Degrees at 3.912/6.138 GHz								
-3 dB	< 0.54	< 0.36						
-15 dB	< 1.14	< 0.75						
Pattern Beamwidth in Degrees at 3.950/6.175 GHz								
-3 dB			< 0.54	< 0.36			< 0.18	< 0.15
-15 dB			< 1.13	< 0.75			< 0.38	< 0.32
Pattern Beamwidth in Degrees at 11.850/14.250 GHz								
-3 dB								
-15 dB								
Sidelobes								
First Sidelobe Level across the band								
Meets FCC Regulation 25.209, Eutelsat, IESS (Intelsat)								
or CCIR Recommendation 580 for Sidelobe Specifications								
Cross Polarization Isolation								
On Axis	30.8 dB	30.8 dB	35.0 dB	35.0 dB	35.0 dB	35.0 dB	35.0 dB	35.0 dB
Within 1 dB Beamwidth	30.8 dB	30.8 dB	30.0 dB	30.0 dB	30.0 dB	30.0 dB	30.0 dB	30.0 dB
VSWR	1.25:1	1.25:1	1.25:1	1.25:1	1.25:1	1.25:1	1.30:1	1.25:1
Feed Insertion or Ohmic Loss	0.15 dB	0.20 dB	0.15 dB	0.20 dB	0.40 dB	0.40 dB	0.50 dB	0.50 dB
Receive-to-Receive Port Isolation	21.0 dB		30.0 dB				30.0 dB	
Transmit-to-Transmit Port Isolation		23.0 dB		30.0 dB				30.0 dB
Transmit-to-Receive Isolation	30.0 dB	30.0 dB	30.0 dB	30.0 dB	30.0 dB	30.0 dB	50.0 dB	85.0 dB
Transmit-to-Receive Isolation with Optional Filter	30.0 dB	85.0 dB	30.0 dB	85.0 dB				
Axial Ratio (Voltage Axial Ratio)	0.50 dB (1.06)	0.50 dB (1.06)						
Feed Interfaces	CPR-229G	CPR-159G	CPR-229G	CPR-159G	WR-75 Flat	WR-75 Flat	WR-75 Flat	WR-75 Flat
Total Power Handling Capability**	10 kW CW	10 kW CW	10 kW CW	10 kW CW	2 kW CW	2 kW CW	2 kW CW	2 kW CW

-14 ± 2 dB

* Other Operational Frequencies Available
 ** Power handling capability is based on and limited by the physical characteristics in the feed components.
 Microwave power at these levels may contribute to radiation hazard or exceed certain off-axis E.I.R.P. specifications.

NOTE: All values are at the rear feed output flange.

VERTEX 9-METER

MODEL 9 KPC & KPK (Kingpost Pedestal)

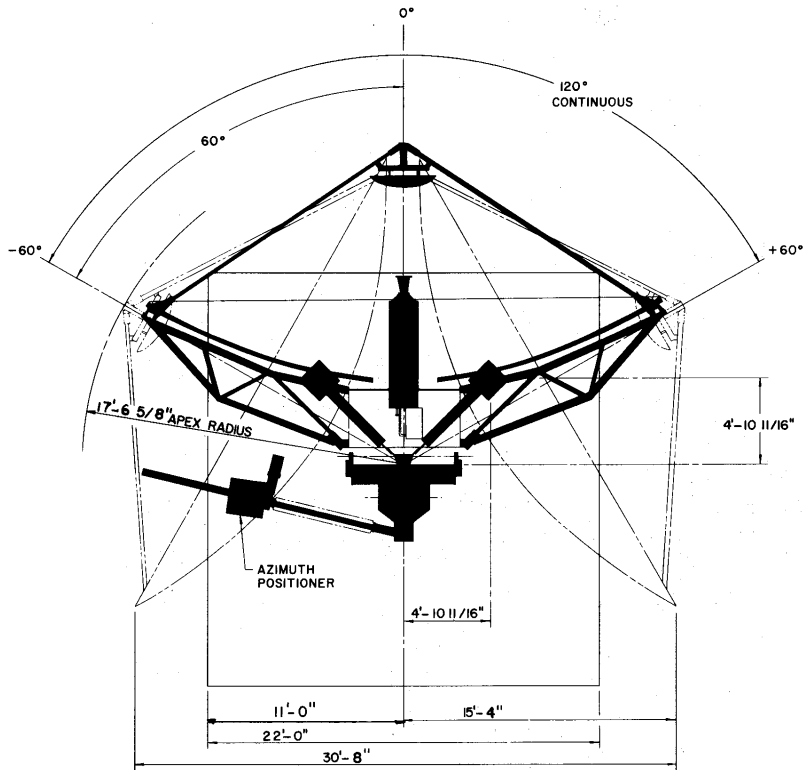

PLAN VIEW

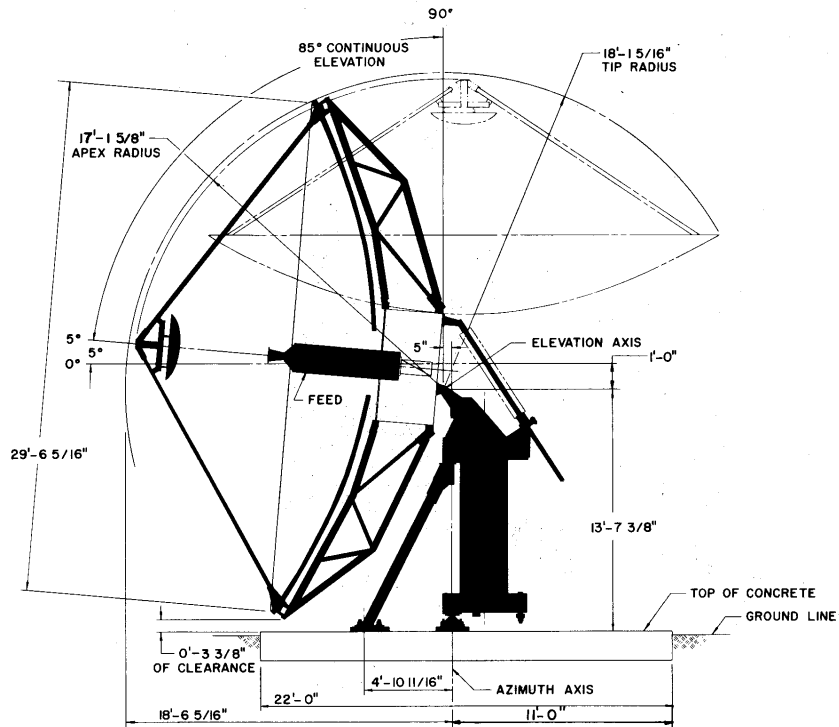

SIDE ELEVATION

VERTEX COMMUNICATIONS CORPORATION

2600 LONGVIEW ST. • P.O. BOX 1277 • KILGORE, TX 75663 • TEL 903-984-0555 • FAX 903-984-1826

HUDSON-LONGVIEW 9076-70 (Rev. 9/93)